

MAGNETIC DIMMABLE DRIVER

INSTALLATION GUIDE

SAFETY & WARNINGS

1. This LED Driver is to be installed in accordance with Article 450 of the National Electrical Code or local code.
2. This product is intended to be installed and serviced by a qualified, licensed electrician.
3. Install in a well-ventilated area free from explosive gases and vapors.
4. This LED Driver must be grounded in accordance with the NEC or local codes. This driver must be grounded to the green grounding wire.
5. Only install compatible dimmable LED fixtures.
6. Ensure applicable wire is installed between driver and fixture. When choosing wire, factor in voltage drop, amperage rating, and type (in-wall rated, wet location rated, etc.). Inadequate wire installation could overheat wires, and cause a fire.
7. See dimmer switch specifications for minimum load requirements.
8. For wet location installations, ensure to mount driver vertically and in a location where water cannot pool or collect.
9. Do not modify or disassemble this product beyond instructions or the warranty will be void.

QUICK SPECS

Input Voltage	
Output Voltage	See Product Label.
Maximum Load	
Ambient Temp †	-4° ~ 122°F (-20° ~ 50°C)
Environment	Wet Location / Outdoor / NEMA 3 Enclosure

INPUT VOLTAGE NOTE!

The driver label will indicate the input voltage: 120VAC or 277VAC. ENSURE to power the driver with the correct voltage!

INSTALLATION

<p>1 TURN POWER OFF AT CIRCUIT BREAKER</p> <p>SHOCK HAZARD! May result in serious injury or death. Turn power OFF at circuit breaker prior to installation.</p>	
<p>2 DETERMINE LOCATION TO INSTALL COMPONENTS</p>	<p>1. Compatible Control 2. Driver 3. Fixture</p>
<p>3 MOUNT DRIVER</p> <p>For proper heat dissipation, mount vertically to a sturdy surface with mounting tab at top and wiring compartment at bottom. For wet location installations, ensure to mount driver vertically in a location where water cannot pool or collect.</p>	<p>YES NO</p>
<p>4 REMOVE WIRING COVER. WIRE DRIVER.</p> <p>Pop off cover to access wiring compartment. Remove knockouts with hammer and punch.</p> <p>Attach load and control. Only use copper wiring. Refer to 'System Diagrams', and dimming control installation guides. Ensure to install a compatible dimming control listed on the 'MAGNETIC DIMMABLE DRIVER Compatibility List' available at www.gllite.com</p>	<p>Cover Port</p> <p>2x Knockouts</p>

INSTALLATION CONT.

5 TURN POWER ON AT CIRCUIT BREAKER

Install Additional Components, Verify connections and turn main power ON at breaker.

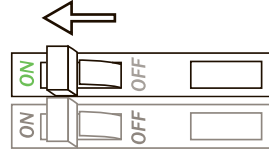

SYSTEM WORKING IMPROPERLY?

Turn power OFF at circuit breaker and verify all connections. Review WIRING and TROUBLESHOOTING or call Goodlite LED Technical Support at 718-697-7502

CIRCUIT BREAKERS

AUTO RESET BREAKER (120VAC 20W - 100W & All Multi-Tap Models)

Both primary and secondary circuits are protected with an automatic reset breaker. A tripped circuit is indicated by the load powering off. Reset may take between 50 seconds and 5 minutes depending on load size.

MANUAL RESET BREAKER (120VAC 200W - 300W, All 277VAC, & Multi-Tap Models)

Both primary and secondary circuits are protected with a single reset breaker in the event of an overload, surge, or short circuit. A tripped circuit is indicated by a popped out, white edge. To reset, turn off main power and push in button.



1 If breaker trips (indicated by a white edge), turn OFF main power and push in to reset



2 Breaker is now reset.

SYSTEM DIAGRAMS

The following diagrams are provided as example system designs. Install in accordance with national and local electrical code regulations.

DIAGRAM KEY

- L = Line (Black)
- B = Line Boost Tap (Orange)
- N = Neutral (White)
- GND = Ground (Green)
- V+ = Low Voltage Positive (Red)
- V- = Low Voltage Negative (Blue)

STANDARD DIMMER/DRIVER DIAGRAM

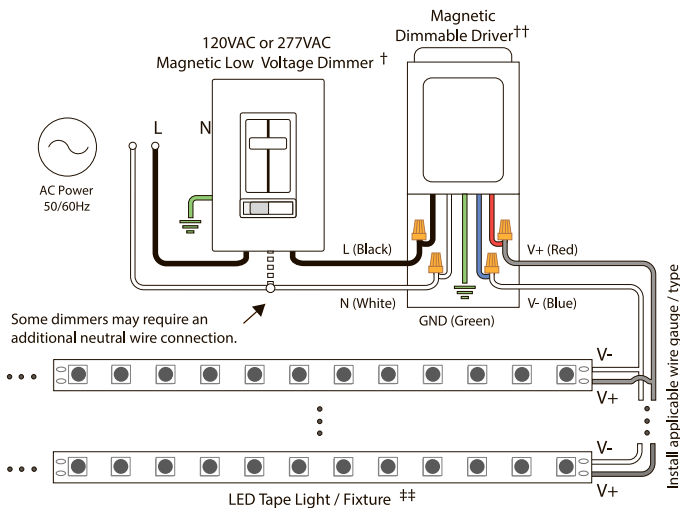

MULTI-TAP DRIVER DIAGRAM

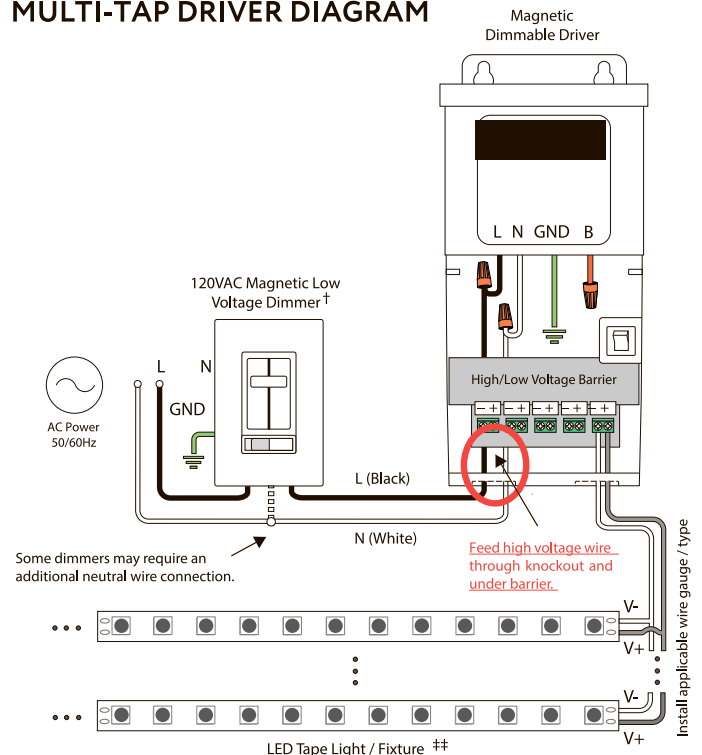

† Install a compatible magnetic low voltage dimmer switch. See dimmer switch manufacturer installation guide for complete wiring instructions.

‡ See fixture specifications for maximum series run limits.

SYSTEM DIAGRAMS CONT.

3-WAY DIMMER/DRIVER DIAGRAM

Also applies to Multi-Tap Models.

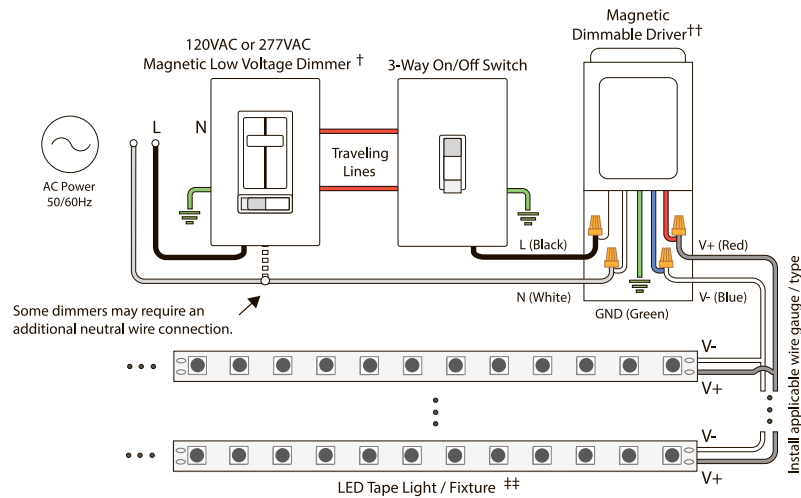

ADDITIONAL RESOURCES

Visit the online product page at www.gllite.com for additional product specifications & warranty information.

MAGNETIC DIMMABLE DRIVER SPECIFICATION SHEET

For full specifications.

MAGNETIC DIMMABLE DRIVER COMPATIBILITY LIST

For a list of compatible dimming controls.

TROUBLESHOOTING

Prior to troubleshooting, ensure all items are a compatible system and main power is turned ON.

FIXTURE DOES NOT ILLUMINATE

- See 'System Diagrams' and installation guides of all components. Ensure the system is wired correctly and polarities are correct.
- Ensure the driver and fixture have the same voltage specifications (12V & 12V, or 24V & 24V).
- Ensure manual reset breaker has not tripped (200W-300W Models)

FIXTURE DOES NOT DIM

- Ensure a compatible constant voltage dimmable fixture is installed.
- Ensure a compatible dimming control is installed and wired correctly. See 'MAGNETIC DIMMABLE DRIVER Compatibility List.'

DIFFERENT FIXTURE TYPES DO NOT DIM IN SYNC

- Different fixture types have different circuit designs and may react differently when dimmed. Ensure each fixture type is installed on a separate dimmable driver for best performance.

FIXTURE IS QUICKLY FLASHING OR FLICKERING

- Verify a compatible dimming control is installed.
- Ensure a compatible constant voltage dimmable fixture is installed.
- Ensure all connections are properly secured.
- Ensure fixture is receiving the correct input voltage.

FIXTURE IS SLOWLY FLASHING

- Ensure driver is not overloaded. An overloaded driver will cause the internal auto-reset to trip repeatedly (20W-100W Models).

INSTALLATION TRIPS MAIN BREAKER

- Check wiring for short circuit. If breaker continues to trip there may be a short in the driver. Call customer support for a replacement driver.

VOLTAGE DROP CHARTS

For best performance and lumen output, ensure proper wire gauge is installed to compensate for voltage drop of low voltage circuits.

Example: 12V Voltage Drop & Wire Length Distance Chart

Wire Gauge	10 W .83 A	20 W 1.7 A	30 W 2.5 A	40 W 3.3 A	50 W 2.1 A	60 W 4.2 A
18 AWG	34 ft.	17 ft.	11 ft.	8 ft.	6 ft.	5 ft.
16 AWG	54 ft.	27 ft.	18 ft.	13 ft.	10 ft.	9 ft.
14 AWG	86 ft.	43 ft.	29 ft.	21 ft.	17 ft.	14 ft.
12 AWG	134 ft.	68 ft.	45 ft.	34 ft.	27 ft.	22 ft.
10 AWG	199 ft.	99 ft.	66 ft.	49 ft.	39 ft.	33 ft.

1 Determine load size. Let's assume load is 55 W. Round up to nearest load.

2 Determine distance from driver to load. Let's assume the distance is 20 ft.

3 It's recommended to install 12 AWG to eliminate excess voltage drop.

12V Voltage Drop & Wire Length Distance Chart

Wire Gauge	10 W .83 A	20 W 1.7 A	30 W 2.5 A	40 W 3.3 A	50 W 2.1 A	60 W 4.2 A
18 AWG	34 ft.	17 ft.	11 ft.	8 ft.	6 ft.	5 ft.
16 AWG	54 ft.	27 ft.	18 ft.	13 ft.	10 ft.	9 ft.
14 AWG	86 ft.	43 ft.	29 ft.	21 ft.	17 ft.	14 ft.
12 AWG	134 ft.	68 ft.	45 ft.	34 ft.	27 ft.	22 ft.
10 AWG	199 ft.	99 ft.	66 ft.	49 ft.	39 ft.	33 ft.

24V Voltage Drop & Wire Length Distance Chart

Wire Gauge	10 W .42 A	20 W .83 A	30 W 1.3 A	40 W 1.7 A	50 W 2.1 A	60 W 2.5 A	70 W 2.9 A	80 W 3.3 A	100 W 4.2 A
18 AWG	134 ft.	68 ft.	45 ft.	33 ft.	27 ft.	22 ft.	19 ft.	17 ft.	14 ft.
16 AWG	215 ft.	109 ft.	72 ft.	54 ft.	43 ft.	36 ft.	31 ft.	27 ft.	22 ft.
14 AWG	345 ft.	174 ft.	115 ft.	86 ft.	69 ft.	57 ft.	49 ft.	43 ft.	36 ft.
12 AWG	539 ft.	272 ft.	181 ft.	135 ft.	108 ft.	90 ft.	77 ft.	68 ft.	56 ft.
10 AWG	784 ft.	397 ft.	263 ft.	197 ft.	158 ft.	131 ft.	112 ft.	98 ft.	82 ft.



Call: 718-697-7502
 Fax: 718 697-7503
www.gllite.com
Sales@gllite.com

© GOODLITE.
 All rights reserved.
 Specifications are subject to change without notice.